

Bespoke

Large Diameter

Fittings to Suit any Pipe Specification

 **TRAN-SIG-MA**

Jsmé s Vámi již od roku 1990



PIONEERS IN PIPE SOLUTIONS

CRANE

BUILDING SERVICES & UTILITIES

 **TRAN-SIG-MA**

distributor Viking Johnson pro ČR



Robust, Reliable, Proven Solution for New Lay Pipes

Customer Specifications

The dedicated range is designed for use with new-lay pipes and other specified situations where the pipe material and nominal sizes are known in advance. Customers can choose from Viking Johnson's standard range or have them custom made to suit a range of diameters and working pressures. This flexibility makes Viking Johnson the natural choice for most major pipeline projects.



Design Liaison

Viking Johnson has worked with clients, consultants and contractors all over the world, assisting in the selection of the product most appropriate to each individual project. Such assistance can include detailed design co-operation with specifying engineers, site visits to aid successful installation, specially designed products to suit project requirements, proof testing in our comprehensive in-house test facility and handling of the extensive documentation and inspection requirements often associated with large projects.

Designed for Flexibility

For pipeline design and installation engineers, the Viking Johnson large diameter couplings are extremely versatile. Each coupling sleeve is internally barrelled, allowing greater angular deflection. Ideal when accommodating misaligned pipes.

Product Capability

Large diameter couplings and flange adaptors are available in a wide range of sizes to suit virtually any customer requirement. Products can be supplied to suit all standard and non standard pipe diameters from DN350 to DN4000. Stepped couplings join pipes of different external diameters and flange adaptors can be supplied with flanges drilled to any national or international standard, or to customers' own specification with a pressure up to 80bar.

Approvals

All products are designed and manufactured under quality management systems certified to ISO 9001 and conform to the American Water Works Association's specification AWWA/ANSI C219 for bolted couplings.

Pipe Materials



Large Diameter Couplings

Product Design Benefits

Corrosion Protection

Metal components are coated with Rilsan Nylon 11, which is WRAS approved for use with potable water, and offers long term corrosion protection and resistance to impact damage.

The nuts & bolts are Sheraplex coated to WIS 4-52-03, which does not gall when re-used and offers a consistent "torque / load" ratio reducing the sensitivity during installation while providing long term corrosion protection.

Cold Expansion

Conforming to AWWA C219 the end ring and centre sleeve are cold expanded, which increases the strength of the steel through work hardening, ensures roundness of manufacture and verifies structural integrity of the material with loads substantially greater than in service.



Flash Butt Welding

Flash butt welding used for end ring and centre sleeve ensuring a full penetration weld with totally homogeneous material and no impurities.

Captive Bolts

Captive non-rotating bolt heads require just a single spanner to install.

Sleeve Length

Standard and long sleeve lengths available to accommodate site conditions.

Internal Barrelling of Sleeve

Internal barrelling of sleeve to accommodate angular deflection of up to 6° (size dependant).

Various Gasket Grades

EPDM (water quality approved) and Nitrile gaskets as standard. Alternative exotic grades available for specialist applications (see Design Data for more details).

Customer Benefits

- Couplings can absorb up to 10mm expansion and contraction, which allows for movement on bridge crossings, in chambers and pump stations. Often eliminates the need for special expansion joints.
- Couplings can offer up to 6° of angular deflection; to allow for the connection of misaligned pipes, take up ground settlement at structures, lay pipes to large radius bends, etc.
- The standard finish for all Viking Johnson products is black Rilsan Nylon 11, which is highly resistant to impact, corrosion, abrasion and chemical attack. However, other coatings such as shopcoat, hot dip galvanising, zinc spray and epoxy coating can be supplied as required.

Large Diameter Flange Adaptors

Product Design Benefits

Corrosion Protection

Metal components are coated with Rilsan Nylon 11, which is WRAS approved for use with potable water, and offers long term corrosion protection and resistance to impact damage.

The nuts & bolts are Sheraplex coated to WIS 4-52-03, which does not gall when re-used and offers a consistent “torque / load” ratio reducing the sensitivity during installation while providing long term corrosion protection.

Cold Expansion

Conforming to AWWA C219 the end ring and centre sleeve are cold expanded, which increases the strength of the steel through work hardening, ensures roundness of manufacture and verifies structural integrity of the material with loads substantially greater than in service.



Flash Butt Welding

Flash butt welding used for end ring and centre sleeve ensuring a full penetration weld with totally homogeneous material and no impurities.

Clear and Full Bore Flange

As standard flange adaptors are supplied with clear bore to slide over pipe for easy installation on site.

Full “S Bore” flange also available for use with wafer style (butterfly) valves.

Flange Drilling

Flange drilling to any standard to accommodate site requirements

Sleeve Length

Standard and long sleeve lengths available to accommodate site conditions.

End Load Forces

Notching of end ring permits the use of tie rods to harness the flange adaptor to accommodate end load forces.

Various Gasket Grades

EPDM (water quality approved) and Nitrile gaskets as standard. Alternative exotic grades available for specialist applications (see Design Data for more details).

Customer Benefits

- ▶ Flange adaptors can absorb up to 5mm expansion, which allows for movement on bridge crossings, in chambers and pump stations. Often eliminates the need for special expansion joints.
- ▶ Flange adaptors can offer up to 3° of angular deflection, to allow for the connection of miss aligned pipe to flange equipment and movement/settlement in service.
- ▶ The standard finish for all Viking Johnson products is black Rilsan Nylon 11, which is highly resistant to impact, corrosion, abrasion and chemical attack. However, other coatings such as shopcoat, hot dip galvanising, zinc spray and epoxy coating can be supplied as required.

Large Diameter Couplings OD355.6 - 816

Specifications

L= Distance back from end of pipe that must be rounded, meet tolerances, and free from any wrapping to ensure correct assembly.

Coupling Type	Coupling Section Type	Sleeve Length S (mm)	Dimensions (mm)		Setting Gap X (mm)		Bolt Details		
			Distance L	Overall C	Min.	Max.	Bolt Dia.	Length (mm)	Torque (Nm)
Standard Sleeve	L02	150	150	243	25	50	M12	235	55 - 65
Long Sleeve	L03	250	200	348	25	150	M12	340	55 - 65
Standard Sleeve	YF2	178	150	276	38	76	M16	265	95 - 120
Long Sleeve	YF3	250	200	351	38	150	M16	340	95 - 120
Standard Sleeve	A2E	178	150	276	38	76	M16	265	95 - 120
Long Sleeve	A2H	254	200	351	38	150	M16	340	95 - 120
Standard Sleeve	XSXG	254	200	411	57	117	M16	400	95 - 120

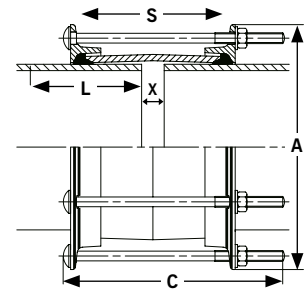

- NOTES**
- General** Viking Johnson manufacture couplings to any pipe OD and pressure. If the product required is not shown in any of our tables please contact Viking Johnson who can provide the relevant information.
 - Pressure** Working pressure is as shown in the table.
Site test pressure is 1.5x working pressure.
 - End Restraint** Dedicated couplings DO NOT resist end load due to the internal pressure - adequate external restraint must be provided to prevent pipe pull out from the coupling.

Pipe OD (mm)	Pipe Material	Working Pressure (bar)	Gasket Mould No.	Tolerance (mm) on Pipe OD for Distance L (mm)		Coupling Section Type		Bolts No. x Dia	Weight (kg)		Diameter A (mm)
				+	-	Standard Sleeve	Long Sleeve		Standard Sleeve	Long Sleeve	
355.6	Steel & uPVC	23.2	J51LS	1.6	1.6	L02	L03	6 x M12	19.6	26.3	447
355.6	Steel	31.0	J51LS	1.6	1.6	L02	L03	8 x M12	20.0	26.9	447
358.6	Coated Steel	19.6	J51LS	1.6	1.6	L02	L03	6 x M12	19.7	26.5	450
358.6	Coated Steel	30.7	J51LS	1.6	1.6	L02	L03	8 x M12	20.2	27.1	450
378	Ductile Iron	29.2	J52LS	2.7	3.5	L02	L03	8 x M12	21.1	28.4	469
406.4	Steel & uPVC	27.2	J53LS	1.6	1.6	L02	L03	8 x M12	22.4	30.2	497
408.4	Coated Steel	27.0	J53LS	1.6	1.6	L02	L03	8 x M12	22.5	30.4	499
409.6	Coated Steel	27.0	J53LS	1.6	1.6	L02	L03	8 x M12	22.6	30.4	500
429	Ductile Iron	25.8	J54LS	2.8	4.0	L02	L03	8 x M12	23.6	31.7	520
457	Steel & uPVC	24.2	J55LS	1.6	1.6	L02	L03	8 x M12	24.9	33.5	548
460	Coated Steel	24.1	J55LS	1.6	1.6	L02	L03	8 x M12	25.0	33.7	551
480	Ductile Iron	23.1	J56LS	2.9	4.0	L02	L03	8 x M12	26.0	35.1	571
480	Ductile Iron	28.9	J56LS	2.9	4.0	L02	L03	10 x M12	26.5	35.7	571
508	Steel & uPVC	27.4	J57LS	1.6	1.6	L02	L03	10 x M12	27.8	37.4	598
511	Coated Steel	27.2	J57LS	1.6	1.6	L02	L03	10 x M12	27.9	37.6	602
532	Ductile Iron	26.1	J58LS	3.0	4.0	L02	L03	10 x M12	29.0	39.1	624
559	Steel & uPVC	24.9	J59LS	1.6	1.6	L02	L03	10 x M12	30.2	40.7	649
610	Steel & uPVC	22.9	J60LS	1.6	1.6	L02	L03	10 x M12	32.7	44.1	701
610	Steel	26.3	J60LS	1.6	1.6	L02	L03	12 x M12	33.1	44.6	701
613	Coated Steel	22.8	J60LS	1.6	1.6	L02	L03	10 x M12	32.8	44.3	704
613	Coated Steel	26.2	J60LS	1.6	1.6	L02	L03	12 x M12	33.2	44.8	704
635	Ductile Iron	22.0	J61LS	3.2	4.5	L02	L03	10 x M12	33.9	45.8	726
635	Ductile Iron	25.2	J61LS	3.2	4.5	L02	L03	12 x M12	34.3	46.3	726
660	Steel	24.3	J61LS	1.6	1.6	L02	L03	12 x M12	35.5	47.9	751
660	Steel	31.5	J61LS	1.6	1.6	YF2	YF3	10 x M16	62.6	74.5	770
663	Coated Steel	24.3	J61LS	1.6	1.6	L02	L03	12 x M12	35.7	48.1	754
663	Coated Steel	31.4	J61LS	1.6	1.6	YF2	YF3	10 x M16	62.9	74.8	773
711	Steel	22.6	J63LS	1.6	1.6	L02	L03	12 x M12	38.1	51.3	802
714	Coated Steel	22.4	J63LS	1.6	1.6	L02	L03	12 x M12	38.1	51.5	805
738	Ductile Iron	21.7	J63LS	3.4	4.5	L02	L03	12 x M12	39.3	53.1	830
738	Ductile Iron	28.2	J63LS	3.4	4.5	YF2	YF3	10 x M16	69.3	82.4	849
762	Steel	21.0	J64LS	1.6	1.6	L02	L03	12 x M12	40.4	54.6	852
762	Steel	27.3	J64LS	1.6	1.6	YF2	YF3	10 x M16	71.2	84.6	871
765	Coated Steel	21.0	J64LS	1.6	1.6	L02	L03	12 x M12	40.6	54.8	856
765	Coated Steel	27.2	J64LS	1.6	1.6	YF2	YF3	10 x M16	71.5	85.0	875
813	Steel	19.8	J65LS	1.6	1.6	L02	L03	14 x M12	43.3	58.5	903
816	Coated Steel	19.7	J65LS	1.6	1.6	L02	L03	14 x M12	43.3	58.7	906

Every effort has been made to ensure that the information contained in this publication is accurate at the time of publishing. Crane Ltd assumes no responsibility or liability for typographical errors or omissions or for any misinterpretation of the information within the publication and reserves the right to change without notice.

Large Diameter Couplings OD842 - 2038

Specifications

Pipe OD (mm)	Pipe Material	Working Pressure (bar)	Gasket Mould No.	Tolerance (mm) on Pipe OD for Distance L		Coupling Section Type		Bolts No. x Dia	Weight (kg)		Diameter A (mm)
				+	-	Standard Sleeve	Long Sleeve		Standard Sleeve	Long Sleeve	
842	Ductile Iron	18.9	J65LS	1.0	4.5	L02	L03	14 x M12	44.6	60.3	931
842	Ductile Iron	25.0	J65LS	1.0	4.5	YF2	YF3	12 x M16	78.7	93.6	950
842	Ductile Iron	29.1	J116M	1.0	4.5	A2E	A2H	14 x M16	103.4	122.7	965
864	Steel	17.9	J66LS	1.6	1.6	L02	L03	14 x M12	45.7	61.8	955
864	Steel	28.4	J116M	1.6	1.6	A2E	A2H	14 x M16	105.9	125.8	988
867	Coated Steel	17.8	J66LS	1.6	1.6	L02	L03	14 x M12	45.9	62.0	958
867	Coated Steel	28.2	J117M	1.6	1.6	A2E	A2H	14 x M16	106.3	126.2	992
914	Steel	16.0	J67LS	1.6	1.6	L02	L03	14 x M12	48.2	65.1	1005
914	Steel	26.8	J117M	1.6	1.6	A2E	A2H	14 x M16	111.6	132.4	1039
916	Coated Steel	16.0	J67LS	1.6	1.6	L02	L03	14 x M12	48.3	65.2	1007
916	Coated Steel	26.8	J117M	1.6	1.6	A2E	A2H	14 x M16	111.8	132.7	1041
945	Ductile Iron	22.0	J70LS	1.0	5.0	YF2	YF3	12 x M16	87.5	104.0	1054
945	Ductile Iron	25.9	J118M	1.0	5.0	A2E	A2H	14 x M16	115.0	136.5	1069
1016	Steel	19.6	J71LS	1.6	1.6	YF2	YF3	14 x M16	94.3	112.2	1125
1019	Coated Steel	19.4	J71LS	1.6	1.6	YF2	YF3	14 x M16	94.6	112.5	1129
1048	Ductile Iron	18.4	J71LS	1.0	5.0	YF2	YF3	14 x M16	96.9	115.3	1156
1048	Ductile Iron	26.8	J119M	1.0	5.0	A2E	A2H	16 x M16	127.1	151.0	1171
1067	Steel	17.7	J72LS	1.6	1.6	YF2	YF3	14 x M16	98.6	117.3	1177
1067	Steel	26.3	J119M	1.6	1.6	A2E	A2H	16 x M16	129.4	153.7	1192
1070	Coated Steel	17.6	J72LS	1.6	1.6	YF2	YF3	14 x M16	98.9	117.6	1180
1070	Coated Steel	26.2	J120M	1.6	1.6	A2E	A2H	16 x M16	129.7	154.1	1195
1118	Steel	16.2	J73LS	1.6	1.6	YF2	YF3	14 x M16	102.9	122.4	1227
1121	Coated Steel	16.0	J73LS	1.6	1.6	YF2	YF3	14 x M16	103.2	122.8	1231
1152	Ductile Iron	24.4	J121M	1.0	6.0	A2E	A2H	16 x M16	138.7	164.7	1275
1219	Steel	23.0	J121M	1.6	1.6	A2E	A2H	16 x M16	146.3	173.7	1343
1222	Coated Steel	23.0	J121M	1.6	1.6	A2E	A2H	16 x M16	146.6	174.1	1347
1255	Ductile Iron	25.2	J122M	1.0	6.0	A2E	A2H	18 x M16	151.0	179.4	1378
1422	Steel	24.5	J125M	1.6	3.0	A2E	A2H	20 x M16	170.5	202.6	1546
1426	Coated Steel	24.4	J125M	1.6	3.0	A2E	A2H	20 x M16	171.0	203.1	1551
1462	Ductile Iron	23.8	J125M	1.0	7.0	A2E	A2H	20 x M16	174.8	207.7	1585
1620	Steel	20.3	J127M	3.0	3.0	A2E	A2H	24 x M16	192.4	230.9	1745
1626	Coated Steel	20.2	J127M	3.0	3.0	A2E	A2H	24 x M16	194.2	231.7	1751
1668	Ductile Iron	19.2	J128M	1.0	7.0	A2E	A2H	24 x M16	199.4	237.0	1791
1829	Steel	16.0	J130M	3.0	3.0	A2E	A2H	24 x M16	217.5	258.5	1954
1835	Coated Steel	24.0	J184H	3.0	3.0	XSXG	-	32 x M16	378.4	-	1970
2032	Steel	22.1	J186H	3.0	3.0	XSXG	-	36 x M16	418.6	-	2167
2038	Coated Steel	22.0	J186H	3.0	3.0	XSXG	-	36 x M16	419.7	-	2173

Materials & Relevant Standards

Centre Sleeve/End Rings

Steel to BS EN10025-2: Grade S275JR

Bolts/Nuts/Washers

Bolts - Steel to BS EN ISO898-1: Property Class 4.8

Nuts - Steel to BS4190: Grade 4

Washers - Stainless Steel to BS1449:Part 2: Grade 304S15

Coatings

Body, Flange & End Ring - Rilsan Nylon 11 to WIS 4-52-01 Part 1

Nuts and Bolts - Sheraplex coated to WIS 4-52-03

Gaskets: L02/L03/YF2/YF3

Rubber 80 IRHD Moulded Compound to BS EN681-1:

Type WA,WC,WG or BS EN682: Type G

(other materials available on request)

Gaskets: A2E/A2H/XSXG

Rubber 70 IRHD Moulded Compound to BS EN681-1: Type WA, WC, WG or BS EN682: Type G (other materials available on request)

Every effort has been made to ensure that the information contained in this publication is accurate at the time of publishing. Crane Ltd assumes no responsibility or liability for typographical errors or omissions or for any misinterpretation of the information within the publication and reserves the right to change without notice.

Large Diameter Stepped Couplings OD355.6 - 1222

Specifications

L = Distance back from end of pipe that must be rounded, meet tolerances, and free from any wrapping to ensure correct assembly.

Coupling Type	Coupling Section Type	Sleeve Length S (mm)	Dimensions (mm)		Setting Gap X (mm)		Bolt Details		
			Distance L	Overall C	Min.	Max.	Bolt Dia.	Length (mm)	Torque (Nm)
Standard Sleeve	L02	150	150	243	25	50	M12	235	55 - 65
Long Sleeve	L03	250	200	348	25	150	M12	340	55 - 65
Standard Sleeve	YF2	178	150	276	38	76	M16	265	95 - 120
Long Sleeve	YF3	250	200	351	38	150	M16	340	95 - 120
Standard Sleeve	A2E	178	150	276	38	76	M16	265	95 - 120
Long Sleeve	A2H	254	200	351	38	150	M16	340	95 - 120
Standard Sleeve	XSXG	254	200	411	57	117	M16	400	95 - 120

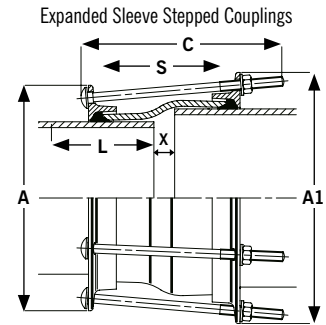

NOTES
General Viking Johnson manufacture stepped couplings to any pipe OD and pressure. If the product required is not shown in any of our tables please contact Viking Johnson who can provide the relevant information.
Pressure Working pressure is as shown in the table. Site test pressure is 1.5x working pressure.
End Restraint Dedicated stepped couplings DO NOT resist end load due to the internal pressure - adequate external restraint must be provided to prevent both pipe pull out from the stepped coupling and also coupling moving along the smaller diameter pipe.

Pipe OD (mm)		Pipe Material End 1	Tolerance on Pipe OD for Distance L		Pipe Material End 2	Tolerance on Pipe OD for Distance L		Working Pressure (bar)	Gasket Mould No.		Coupling Section Type		Bolts No. x Dia	Weight (kg)		Dimensions (mm)		Bolt Length		Dimensions Overall C	
End 1	End 2		(mm) +	(mm) -		(mm) +	(mm) -		End 1	End 2	Standard Sleeve	Long Sleeve		Standard Sleeve	Long Sleeve	Diameter A End 1	Diameter A1 End 2	Standard Sleeve	Long Sleeve	Standard Sleeve	Long Sleeve
355.6	378	Steel & uPVC	1.6	1.6	Ductile Iron	2.7	3.5	29.2	J51LS	J52LS	L02	L03	8 x M12	20.7	27.8	446	469	235	340	243	348
358.6	378	Coated Steel	1.6	1.6	Ductile Iron	2.7	3.5	29.2	J51LS	J52LS	L02	L03	8 x M12	20.7	27.8	450	469	235	340	243	348
406.4	429	Steel & uPVC	1.6	1.6	Ductile Iron	2.8	4.0	25.7	J53LS	J54LS	L02	L03	8 x M12	23.1	31.1	497	520	235	340	243	348
409.6	429	Coated Steel	1.6	1.6	Ductile Iron	2.8	4.0	25.7	J53LS	J54LS	L02	L03	8 x M12	23.2	31.2	499	520	235	340	243	348
457	480	Steel & uPVC	1.6	1.6	Ductile Iron	2.9	4.0	23.1	J55LS	J56LS	L02	L03	8 x M12	25.6	34.5	548	571	235	340	243	348
460	480	Coated Steel	1.6	1.6	Ductile Iron	2.9	4.0	23.1	J55LS	J56LS	L02	L03	8 x M12	25.7	34.5	551	571	235	340	243	348
480	508	Ductile Iron	2.9	4.0	Steel & uPVC	1.6	1.6	27.3	J56LS	J57LS	L02	L03	10 x M12	27.3	36.7	571	598	235	340	243	348
480	511	Ductile Iron	2.9	4.0	Coated Steel	1.6	1.6	27.2	J56LS	J57LS	L02	L03	10 x M12	27.5	36.9	571	602	235	340	243	348
508	532	Steel & uPVC	1.6	1.6	Ductile Iron	3.0	4.0	26.1	J57LS	J58LS	L02	L03	10 x M12	28.6	38.4	598	624	235	340	243	348
511	532	Coated Steel	1.6	1.6	Ductile Iron	3.0	4.0	26.1	J57LS	J58LS	L02	L03	10 x M12	28.6	38.5	602	624	235	340	243	348
610	635	Steel & uPVC	1.6	1.6	Ductile Iron	3.2	4.5	22.0	J60LS	J61LS	L02	L03	10 x M12	33.6	45.2	700	726	235	340	243	348
613	635	Coated Steel	1.6	1.6	Ductile Iron	3.2	4.5	22.0	J60LS	J61LS	L02	L03	10 x M12	33.6	45.2	703	726	235	340	243	348
711	738	Steel	1.6	1.6	Ductile Iron	3.4	4.5	21.7	J63LS	J63LS	L02	L03	12 x M12	39.0	52.5	802	830	235	340	243	348
714	738	Coated Steel	1.6	1.6	Ductile Iron	3.4	4.5	21.7	J63LS	J63LS	L02	L03	12 x M12	39.0	52.5	805	830	235	340	243	348
738	747	Ductile Iron	3.4	4.5	Cast Iron CD	3.3	3.3	21.3	J63LS	J63LS	L02	L03	12 x M12	39.4	53.2	830	839	235	340	243	348
738	755	Ductile Iron	3.4	4.5	Cast Iron AB	3.3	3.3	21.2	J63LS	J65LS	L02	L03	12 x M12	39.9	53.7	830	847	235	340	243	348
813	842	Steel	1.6	1.6	Ductile Iron	1.0	4.5	18.8	J65LS	J65LS	L02	L03	14 x M12	44.4	59.7	903	931	235	340	243	348
816	842	Coated Steel	1.6	1.6	Ductile Iron	1.0	4.5	18.8	J65LS	J65LS	L02	L03	14 x M12	44.4	59.8	906	931	235	340	243	348
826	842	Cast Iron CD	3.3	3.3	Ductile Iron	1.0	4.5	18.8	J65LS	J65LS	L02	L03	14 x M12	44.3	59.8	918	931	235	340	243	348
842	886	Ductile Iron	1.0	4.5	Cast Iron AB	3.3	3.3	17.0	J65LS	J65LS	-	L03	14 x M12	-	62.7	931	978	-	340	-	348
906	945	Cast Iron CD	3.3	3.3	Ductile Iron	1.0	5.0	22.0	J67LS	J70LS	YF2	YF3	12 x M16	86.5	102.6	1017	1054	265	340	276	351
914	945	Steel	1.6	1.6	Ductile Iron	1.0	5.0	22.0	J67LS	J70LS	YF2	YF3	12 x M16	86.5	102.7	1005	1054	265	340	276	351
916	945	Coated Steel	1.6	1.6	Ductile Iron	1.0	5.0	22.0	J67LS	J70LS	YF2	YF3	12 x M16	86.5	102.7	1007	1054	265	340	276	351
945	964	Ductile Iron	1.0	5.0	Cast Iron AB	3.3	3.3	21.6	J70LS	J70LS	YF2	YF3	12 x M16	88.3	104.9	1054	1075	265	340	276	351
1016	1048	Steel	1.6	1.6	Ductile Iron	1.0	5.0	18.3	J71LS	J71LS	YF2	YF3	14 x M16	95.9	114.1	1125	1156	265	340	276	351
1019	1048	Coated Steel	1.6	1.6	Ductile Iron	1.0	5.0	18.3	J71LS	J71LS	YF2	YF3	14 x M16	95.9	114.2	1129	1156	265	340	276	351
1121	1152	Cast Iron AB	3.3	3.3	Ductile Iron	1.0	6.0	24.3	J120M	J121M	A2E	A2H	16 x M16	137.6	164.9	1247	1275	265	340	276	351
1219	1255	Steel	1.6	1.6	Ductile Iron	1.0	6.0	25.2	J120M	J132M	A2E	A2H	18 x M16	150.1	179.8	1344	1379	265	340	276	351
1222	1255	Coated Steel	1.6	1.6	Ductile Iron	1.0	6.0	25.2	J120M	J132M	A2E	A2H	18 x M16	150.1	179.8	1347	1379	265	340	276	351

Materials & Relevant Standards

Centre Sleeve/End Rings

Steel to BS EN10025-2:2004 Grade S275JR

Bolts/Nuts/Washers

Bolts - Steel to BS EN ISO898-1:2009

Property Class 4.8

Nuts - Steel to BS4190:2001 Grade 4

Washers - Stainless Steel to BS1449:Part 2:1983

Grade 304S15

Every effort has been made to ensure that the information contained in this publication is accurate at the time of publishing. Crane Ltd assumes no responsibility or liability for typographical errors or omissions or for any misinterpretation of the information within the publication and reserves the right to change without notice.

Coatings

Body, Flange & End Ring - Rilsan Nylon 11 to WIS 4-52-01 Part 1

Nuts and Bolts - Sheraplex coated to WIS 4-52-03

Gaskets: L02/L03/YF2/YF3

Rubber 80 IRHD Moulded Compound to BS

EN681-1:1996 Type WA,WC,WG or BS

EN682:2002, Type G (other materials available on request)

Gaskets: A2E/A2H/XSXG

Rubber 70 IRHD Moulded Compound to BS

EN681-1:1996 Type WA, WC, WG or BS

EN682:2002, Type G

(other materials available on request)

Australia - Adelaide

Desalination Plant Transfer Pipeline

Large Diameter Flange Adaptor - DN1600



Project

The Desalination Plant has a capacity of up to 100 gigalitres and will provide Adelaide with up to half its annual water requirement. The huge size of the plant will be powered by sustainable energy sources and will ensure that the majority of the water supply is sourced from the sea with lesser reliance placed on the River Murray basin.

Client

South Australian Water
& South Australian Government

Contractor

McConnell Dowell

Distributor

Philmac



Large Diameter Flange Adaptors OD355 - 1016mm to BS EN 1092-1 PN10 Drilling

Specifications

L = Distance back from end of pipe that must be rounded, meet tolerances, and free from any wrapping to ensure correct assembly.

Flange Adaptor Type	Flange Adaptor Section	Sleeve Length S (mm)	Distance L (mm)	Setting Gap X (mm)		Bolt Details		
				Min.	Max.	Bolt Dia.	Length (mm)	Torque (Nm)
Standard Sleeve	L02	73	150	25	50	M12	140	55 - 65
Long Sleeve	L03	123	200	25	100	M12	180	55 - 65
Standard Sleeve	YF2	87	150	32	76	M16	160	95 - 120
Long Sleeve	YF3	123	200	32	115	M16	190	95 - 120
Standard Sleeve	A2E	87	150	32	76	M16	160	95 - 120
Long Sleeve	A2H	125	200	32	115	M16	190	95 - 120
Standard Sleeve	XSXG	254	200	57	117	M16	400	95 - 120

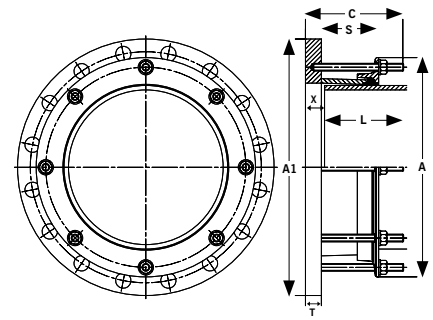

NOTES

- General** Viking Johnson manufacture flange adaptors to any pipe OD and flange drilling. If the product required is not shown in any of our tables please contact Viking Johnson who can provide the relevant information.
- Pressure** Working pressure is in accordance with the flange drilling. Site test pressure is 1.5x working pressure.
- End Restraint** Dedicated flange adaptors DO NOT resist end load due to the internal pressure - adequate external restraint must be provided by either anchoring the pipework or use of tie rods to restrain the flange adaptor and prevent pipe pull out.
- Tie Rods** When using tie rods to provide restraint, depending on the pipe OD & flange drilling the flange adaptor end ring may need to be notched to allow the tie rod to pass over. The table below provides details on :-
 A) Those products that do not require notching (i.e. there is no interference between the tie rods and end ring) - indicated by "Not Rqd."
 B) Those products where there is interference between the tie rod and end ring and do require notching, with the number of notches provided as standard indicated.
- Tie Rod Yield Strength** The number of notches indicated assumes the use of tie rods with a minimum yield strength of 725 N/mm².
 If tie rods with a lower yield strength are used, then depending on the working pressure an increased number than that specified in the table may be required; in this situation please advise Viking Johnson of the number of notches and we will accommodate your requirements.

Pipe OD (mm)	Pipe Material	Flange Drilling BS EN 1092-1		Tolerance on Pipe OD for Distance L		Gasket Mould No.	No. Notches in End Ring if Required	Flange Adaptor Section Type		Flange Adaptor Studs No. x Dia	Weight (kg)		Dimensions						Flange Adaptor Studs Length	
		Nominal	Drilling	(mm) +	(mm) -			Standard Sleeve	Long Sleeve		Standard Sleeve	Long Sleeve	Diameter A (mm)	Flange OD A1 (mm)	Flange Thickness T (mm)	Flange Bolts No. x Dia	Overall C Standard Sleeve (mm)	Overall C Long Sleeve (mm)	Standard Sleeve	Long Sleeve
355.6	Steel & uPVC	350	PN10	1.6	1.6	J51LS	4	L02	L03	8 x M12	22.8	26.2	446	505	18	16 x M20	148	188	140	180
358.6	Coated Steel	350	PN10	1.6	1.6	J51LS	4	L02	L03	8 x M12	22.6	26.1	450	505	18	16 x M20	148	188	140	180
378	Ductile Iron	350	PN10	2.7	3.5	J52LS	8	L02	L03	8 x M12	21.3	24.9	469	505	18	16 x M20	148	188	140	180
406.4	Steel & uPVC	400	PN10	1.6	1.6	J53LS	4	L02	L03	8 x M12	26.3	30.2	497	565	18	16 x M24	148	188	140	180
409.4	Coated Steel	400	PN10	1.6	1.6	J53LS	4	L02	L03	8 x M12	26.1	30.0	500	565	18	16 x M24	148	188	140	180
429	Ductile Iron	400	PN10	2.8	4.0	J54LS	8	L02	L03	8 x M12	24.5	28.6	520	565	18	16 x M24	148	188	140	180
457	Steel & uPVC	450	PN10	1.6	1.6	J55LS	5	L02	L03	10 x M12	33.5	37.9	548	615	23	20 x M24	153	193	140	180
460	Coated Steel	450	PN10	1.6	1.6	J55LS	5	L02	L03	10 x M12	33.2	37.6	551	615	23	20 x M24	153	193	140	180
480	Ductile Iron	450	PN10	2.9	4.0	J56LS	10	L02	L03	10 x M12	30.7	35.2	571	615	23	20 x M24	153	193	140	180
508	Steel & uPVC	500	PN10	1.6	1.6	J57LS	5	L02	L03	10 x M12	37.7	42.5	598	670	23	20 x M24	153	193	140	180
511	Coated Steel	500	PN10	1.6	1.6	J57LS	5	L02	L03	10 x M12	37.3	42.1	602	670	23	20 x M24	153	193	140	180
532	Ductile Iron	500	PN10	3.0	4.0	J58LS	10	L02	L03	10 x M12	34.3	39.3	624	670	23	20 x M24	153	193	140	180
610	Steel & uPVC	600	PN10	1.6	1.6	J60LS	5	L02	L03	10 x M12	45.9	51.6	700	780	23	20 x M27	153	193	140	180
613	Coated Steel	600	PN10	1.6	1.6	J60LS	5	L02	L03	10 x M12	45.4	51.1	703	780	23	20 x M27	153	193	140	180
635	Ductile Iron	600	PN10	3.2	4.5	J61LS	10	L02	L03	10 x M12	41.6	47.5	726	780	23	20 x M27	153	193	140	180
711	Steel	700	PN10	1.6	1.6	J63LS	Not Rqd.	L02	L03	12 x M12	56.1	62.7	802	895	23	24 x M27	153	193	140	180
714	Coated Steel	700	PN10	1.6	1.6	J63LS	6	L02	L03	12 x M12	55.6	62.2	805	895	23	24 x M27	153	193	140	180
738	Ductile Iron	700	PN10	3.4	4.5	J63LS	12	L02	L03	12 x M12	50.8	57.6	830	895	23	24 x M27	153	193	140	180
813	Steel	800	PN10	1.6	1.6	J65LS	Not Rqd.	L02	L03	12 x M12	68.2	75.7	903	1015	23	24 x M30	153	193	140	180
816	Coated Steel	800	PN10	1.6	1.6	J65LS	Not Rqd.	L02	L03	12 x M12	67.6	75.1	906	1015	23	24 x M30	153	193	140	180
842	Ductile Iron	800	PN10	1.0	4.5	J65LS	12	L02	L03	12 x M12	62.2	69.9	931	1015	23	24 x M30	153	193	140	180
914	Steel	900	PN10	1.6	1.6	J67LS	Not Rqd.	L02	L03	14 x M12	79.8	88.2	1005	1115	25	28 x M30	155	195	140	180
916	Coated Steel	900	PN10	1.6	1.6	J67LS	Not Rqd.	L02	L03	14 x M12	79.3	87.7	1007	1115	25	28 x M30	155	195	140	180
945	Ductile Iron	900	PN10	1.0	5.0	J70LS	14	YF2	YF3	14 x M16	89.3	97.5	1054	1115	25	28 x M30	169	199	160	190
1016	Steel	1000	PN10	1.6	1.6	J71LS	7	YF2	YF3	14 x M16	112.4	121.2	1125	1230	25	28 x M33	169	199	160	190

Every effort has been made to ensure that the information contained in this publication is accurate at the time of publishing. Crane Ltd assumes no responsibility or liability for typographical errors or omissions or for any misinterpretation of the information within the publication and reserves the right to change without notice.

Large Diameter Flange Adaptors OD1019 - 1668mm to BS EN 1092-1 PN10 Drilling

Specifications

Pipe OD (mm)	Pipe Material	Flange Drilling BS EN 1092-1		Tolerance on Pipe OD for Distance L		Gasket Mould No.	No. Notches In End Ring If Required	Flange Adaptor Section Type		Flange Adaptor Studs No. x Dia	Weight (kg)		Dimensions						Flange Adaptor Studs Length	
		Nominal	Drilling	(mm) +	(mm) -			Standard Sleeve	Long Sleeve		Standard Sleeve	Long Sleeve	Diameter A (mm)	Flange OD A1 (mm)	Flange Thickness T (mm)	Flange Bolts No. x Dia	Overall C Standard Sleeve (mm)	Overall C Long Sleeve (mm)	Standard Sleeve	Long Sleeve
1019	Coated Steel	1000	PN10	1.6	1.6	J71LS	7	YF2	YF3	14 x M16	111.4	120.3	1129	1230	25	28 x M33	169	199	160	190
1048	Ductile Iron	1000	PN10	1.0	5.0	J71LS	14	YF2	YF3	14 x M16	102.9	112.0	1156	1230	25	28 x M33	169	199	160	190
1118	Steel	1100	PN10	1.6	1.6	J73LS	Not Rqd.	YF2	YF3	16 x M16	126.0	135.7	1227	1340	25	32 x M33	169	199	160	190
1121	Coated Steel	1100	PN10	1.6	1.6	J73LS	8	YF2	YF3	16 x M16	124.9	134.6	1231	1340	25	32 x M33	169	199	160	190
1152	Ductile Iron	1100	PN10	1.0	6.0	J121M	16	A2E	A2H	16 x M16	162.6	175.4	1275	1340	38	32 x M33	182	212	160	190
1219	Steel	1200	PN10	1.6	1.6	J74LS	Not Rqd.	YF2	YF3	16 x M16	141.8	152.3	1329	1455	25	32 x M36	169	199	160	190
1222	Coated Steel	1200	PN10	1.6	1.6	J74LS	Not Rqd.	YF2	YF3	16 x M16	201.1	214.7	1332	1455	25	32 x M36	169	212	160	190
1255	Ductile Iron	1200	PN10	1.0	6.0	J122M	16	A2E	A2H	16 x M16	183.0	196.9	1378	1455	38	32 x M36	182	212	160	190
1422	Steel	1400	PN10	1.6	3.0	J125M	9	A2E	A2H	18 x M16	245.5	261.2	1546	1675	38	36 x M39	182	212	160	190
1426	Coated Steel	1400	PN10	1.6	3.0	J125M	9	A2E	A2H	18 x M16	243.1	258.8	1550	1675	38	36 x M39	182	212	160	190
1462	Ductile Iron	1400	PN10	1.0	7.0	J125M	18	A2E	A2H	18 x M16	220.1	236.2	1585	1675	38	36 x M39	182	212	160	190
1620	Steel	1600	PN10	3.0	3.0	J127M	Not Rqd.	A2E	A2H	20 x M16	309.3	327.2	1745	1915	38	40 x M45	182	212	160	190
1626	Coated Steel	1600	PN10	3.0	3.0	J127M	Not Rqd.	A2E	A2H	20 x M16	304.7	322.6	1751	1915	38	40 x M45	182	212	160	190
1668	Ductile Iron	1600	PN10	1.0	7.0	J128M	20	A2E	A2H	20 x M16	275.2	293.6	1791	1915	38	40 x M45	182	212	160	190

Materials & Relevant Standards

Flange/End Ring

Steel to BS EN10025-2: Grade S275JR

Studs/Nuts/Washers

Studs - Steel to BS EN ISO898-1: Property Class 4.8

Nuts - Steel to BS4190: Grade 4

Washers - Stainless Steel to BS1449:Part 2: Grade 304S15

Coatings

Body, Flange & End Ring - Rilsan Nylon 11 to WIS 4-52-01 Part 1

Nuts and Studs - Sheraplex coated to WIS 4-52-03

Gaskets: L02/L03/YF2/YF3

Rubber 80 IRHD Moulded Compound to BS EN681-1: Type WA,WC,WG or BS EN682: Type G (other materials available on request)

Gaskets: A2E/A2H/XSXG

Rubber 70 IRHD Moulded Compound to BS EN681-1: Type WA, WC, WG or BS EN682: Type G (other materials available on request)

Every effort has been made to ensure that the information contained in this publication is accurate at the time of publishing. Crane Ltd assumes no responsibility or liability for typographical errors or omissions or for any misinterpretation of the information within the publication and reserves the right to change without notice.

Large Diameter Flange Adaptors OD355 - 813mm to BS EN 1092-1 PN16 Drilling

Specifications

L= Distance back from end of pipe that must be rounded, meet tolerances, and free from any wrapping to ensure correct assembly.

Flange Adaptor Type	Flange Adaptor Section	Sleeve Length S (mm)	Distance L (mm)	Setting Gap X (mm)		Bolt Details		
				Min.	Max.	Bolt Dia.	Length (mm)	Torque (Nm)
Standard Sleeve	LO2	73	150	25	50	M12	140	55 - 65
Long Sleeve	LO3	123	200	25	100	M12	180	55 - 65
Standard Sleeve	YF2	87	150	32	76	M16	160	95 - 120
Long Sleeve	YF3	123	200	32	115	M16	190	95 - 120
Standard Sleeve	A2E	87	150	32	76	M16	160	95 - 120
Long Sleeve	A2H	125	200	32	115	M16	190	95 - 120
Standard Sleeve	XSXG	254	200	57	117	M16	400	95 - 120

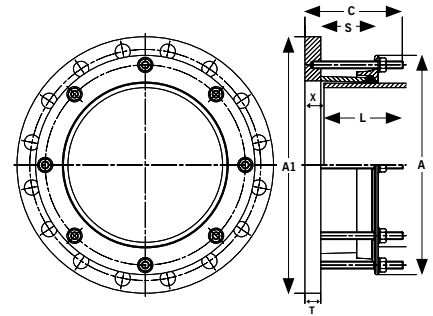

NOTES

- General** Viking Johnson manufacture flange adaptors to any pipe OD and flange drilling. If the product required is not shown in any of our tables please contact Viking Johnson who can provide the relevant information.
- Pressure** Working pressure is in accordance with the flange drilling. Site test pressure is 1.5x working pressure.
- End Restraint** Dedicated flange adaptors DO NOT resist end load due to the internal pressure - adequate external restraint must be provided by either anchoring the pipework or use of tie rods to restrain the flange adaptor and prevent pipe pull out.
- Tie Rods** When using tie rods to provide restraint, depending on the pipe OD & flange drilling the flange adaptor end ring may need to be notched to allow the tie rod to pass over. The table below provides details on :-
 A) Those products that do not require notching (i.e. there is no interference between the tie rods and end ring) - indicated by "Not Rqd."
 B) Those products where there is interference between the tie rod and end ring and do require notching, with the number of notches provided as standard indicated.
- Tie Rod Yield Strength** The number of notches indicated assumes the use of tie rods with a minimum yield strength of 725 N/mm².
 If tie rods with a lower yield strength are used, then depending on the working pressure an increased number than that specified in the table may be required; in this situation please advise Viking Johnson of the number of notches and we will accommodate your requirements.

Pipe OD (mm)	Pipe Material	Flange Drilling BS EN 1092-1		Tolerance on Pipe OD for Distance L		Gasket Mould No.	No. Notches In End Ring If Required	Flange Adaptor Section Type		Flange Adaptor Studs No. x Dia	Weight (kg)		Dimensions						Flange Adaptor Studs Length	
		Nominal	Drilling	(mm) +	(mm) -			Standard Sleeve	Long Sleeve		Standard Sleeve	Long Sleeve	Diameter A (mm)	Flange OD A1 (mm)	Flange Thickness T (mm)	Flange Bolts No. x Dia	Overall C Standard Sleeve (mm)	Overall C Long Sleeve (mm)	Standard Sleeve	Long Sleeve
355.6	Steel & uPVC	350	PN16	1.6	1.6	J51LS	4	L02	L03	8 x M12	24.1	27.5	446	520	18	16 x M24	148	188	140	180
358.6	Coated Steel	350	PN16	1.6	1.6	J51LS	4	L02	L03	8 x M12	23.9	27.3	450	520	18	16 x M24	148	188	140	180
378	Ductile Iron	350	PN16	2.7	3.5	J52LS	8	L02	L03	8 x M12	22.5	26.3	469	520	18	16 x M24	148	188	140	180
406.4	Steel & uPVC	400	PN16	1.6	1.6	J53LS	4	L02	L03	8 x M12	27.9	31.8	497	580	18	16 x M27	148	188	140	180
409.4	Coated Steel	400	PN16	1.6	1.6	J53LS	4	L02	L03	8 x M12	27.7	31.6	500	580	18	16 x M27	148	188	140	180
429	Ductile Iron	400	PN16	2.8	4.0	J54LS	8	L02	L03	8 x M12	26.2	30.2	520	580	18	16 x M27	148	188	140	180
451	PVC & Hep30	450	PN16	0.0	1.0	J55LS	Not Rqd.	L02	L03	10 x M12	45.2	42.4	541	640	25	20 x M27	155	193	140	180
457	Steel & uPVC	450	PN16	1.6	1.6	J55LS	Not Rqd.	L02	L03	10 x M12	37.5	41.9	548	640	23	20 x M27	153	193	140	180
460	Coated Steel	450	PN16	1.6	1.6	J55LS	5	L02	L03	10 x M12	37.2	41.5	551	640	23	20 x M27	153	193	140	180
480	Ductile Iron	450	PN16	2.9	4.0	J56LS	10	L02	L03	10 x M12	34.7	39.3	571	640	23	20 x M27	153	193	140	180
508	Steel & uPVC	500	PN16	1.6	1.6	J57LS	Not Rqd.	L02	L03	10 x M12	45.5	50.3	598	715	23	20 x M30	153	193	140	180
511	Coated Steel	500	PN16	1.6	1.6	J57LS	Not Rqd.	L02	L03	10 x M12	45.1	49.9	602	715	23	20 x M30	153	193	140	180
532	Ductile Iron	500	PN16	3.0	4.0	J58LS	10	L02	L03	10 x M12	42.2	47.2	624	715	23	20 x M30	153	193	140	180
610	Steel & uPVC	600	PN16	1.6	1.6	J60LS	Not Rqd.	L02	L03	10 x M12	58.5	64.2	700	840	23	20 x M33	153	193	140	180
613	Coated Steel	600	PN16	1.6	1.6	J60LS	Not Rqd.	L02	L03	10 x M12	58.0	63.7	703	840	23	20 x M33	153	193	140	180
635	Ductile Iron	600	PN16	3.2	4.5	J61LS	Not Rqd.	L02	L03	10 x M12	54.5	60.4	726	840	23	20 x M33	153	193	140	180
711	Steel	700	PN16	1.6	1.6	J63LS	6	L02	L03	12 x M12	58.5	65.2	802	910	23	24 x M33	153	193	140	180
714	Coated Steel	700	PN16	1.6	1.6	J63LS	6	L02	L03	12 x M12	58.0	64.6	805	910	23	24 x M33	153	193	140	180
738	Ductile Iron	700	PN16	3.4	4.5	J63LS	12	L02	L03	12 x M12	53.1	59.9	830	910	23	24 x M33	153	193	140	180
813	Steel	800	PN16	1.6	1.6	J65LS	Not Rqd.	L02	L03	12 x M12	69.6	77.1	903	1025	23	24 x M36	153	193	140	180

Every effort has been made to ensure that the information contained in this publication is accurate at the time of publishing. Crane Ltd assumes no responsibility or liability for typographical errors or omissions or for any misinterpretation of the information within the publication and reserves the right to change without notice.

Large Diameter Flange Adaptors OD816 - 1668mm to BS EN 1092-1 PN16 Drilling

Specifications

Pipe OD (mm)	Pipe Material	Flange Drilling BS EN 1092-1		Tolerance on Pipe OD for Distance L		Gasket Mould No.	No. Notches In End Ring If Required	Flange Adaptor Section Type		Flange Adaptor Studs No. x Dia	Weight (kg)		Dimensions						Flange Adaptor Studs Length	
		Nominal	Drilling	(mm) +	(mm) -			Standard Sleeve	Long Sleeve		Standard Sleeve	Long Sleeve	Diameter A (mm)	Flange OD A1 (mm)	Flange Thickness T (mm)	Flange Bolts No. x Dia	Overall C Standard Sleeve (mm)	Overall C Long Sleeve (mm)	Standard Sleeve	Long Sleeve
816	Coated Steel	800	PN16	1.6	1.6	J65LS	6	L02	L03	12 x M12	68.9	76.4	906	1025	23	24 x M36	153	193	140	180
842	Ductile Iron	800	PN16	1.0	4.5	J65LS	12	L02	L03	12 x M12	63.4	71.1	931	1025	23	24 x M36	153	193	140	180
914	Steel	900	PN16	1.6	1.6	J67LS	7	L02	L03	14 x M12	81.3	89.7	1005	1125	25	28 x M36	155	195	140	180
916	Coated Steel	900	PN16	1.6	1.6	J67LS	7	L02	L03	14 x M12	80.8	89.2	1007	1125	25	28 x M36	155	195	140	180
945	Ductile Iron	900	PN16	1.0	5.0	J70LS	14	YF2	YF3	14 x M16	90.8	99.1	1054	1125	25	28 x M36	169	199	160	190
1016	Steel	1000	PN16	1.6	1.6	J71LS	7	YF2	YF3	14 x M16	119.8	128.6	1125	1255	25	28 x M39	169	199	160	190
1019	Coated Steel	1000	PN16	1.6	1.6	J71LS	7	YF2	YF3	14 x M16	118.9	127.7	1129	1255	25	28 x M39	169	199	160	190
1048	Ductile Iron	1000	PN16	1.0	5.0	J71LS	14	YF2	YF3	14 x M16	110.4	119.4	1156	1255	25	28 x M39	169	199	160	190
1118	Steel	1100	PN16	1.6	1.6	J73LS	8	YF2	YF3	16 x M16	129.8	139.5	1227	1355	25	32 x M39	169	199	160	190
1121	Coated Steel	1100	PN16	1.6	1.6	J73LS	8	YF2	YF3	16 x M16	128.7	138.5	1231	1355	25	32 x M39	169	199	160	190
1152	Ductile Iron	1100	PN16	1.0	6.0	J121M	16	A2E	A2H	16 x M16	168.0	180.9	1275	1355	38	32 x M39	182	212	160	190
1219	Steel	1200	PN16	1.6	1.6	J121M	8	A2E	A2H	16 x M16	217.4	230.9	1343	1485	38	32 x M45	182	212	160	190
1222	Coated Steel	1200	PN16	1.6	1.6	J121M	8	A2E	A2H	16 x M16	215.8	229.4	1347	1485	38	32 x M45	182	212	160	190
1255	Ductile Iron	1200	PN16	1.0	6.0	J122M	16	A2E	A2H	16 x M16	197.6	211.5	1378	1485	38	32 x M45	182	212	160	190
1422	Steel	1400	PN16	1.6	3.0	J125M	9	A2E	A2H	18 x M16	248.7	264.4	1546	1685	38	36 x M45	182	212	160	190
1426	Coated Steel	1400	PN16	1.6	3.0	J125M	9	A2E	A2H	18 x M16	246.1	261.9	1550	1685	38	36 x M45	182	212	160	190
1462	Ductile Iron	1400	PN16	1.0	7.0	J125M	18	A2E	A2H	18 x M16	223.3	239.4	1585	1685	38	36 x M45	182	212	160	190
1620	Steel	1600	PN16	3.0	3.0	J127M	Not Rqd.	A2E	A2H	20 x M16	315.9	333.7	1745	1930	38	40 x M52	182	212	160	190
1626	Coated Steel	1600	PN16	3.0	3.0	J127M	Not Rqd.	A2E	A2H	20 x M16	311.3	329.2	1751	1930	38	40 x M52	182	212	160	190
1668	Ductile Iron	1600	PN16	1.0	7.0	J128M	20	A2E	A2H	20 x M16	281.3	299.7	1791	1930	38	40 x M52	182	212	160	190

Materials & Relevant Standards

Flange/End Ring

Steel to BS EN10025-2: Grade S275JR

Studs/Nuts/Washers

Studs - Steel to BS EN ISO898-1:

Property Class 4.8

Nuts - Steel to BS4190: Grade 4

Washers - Stainless Steel to BS1449:Part 2:

Grade 304S15

Coatings

Body, Flange & End Ring - Rilsan Nylon 11 to WIS 4-52-01 Part 1

Nuts and Studs - Sheraplex coated to WIS 4-52-03

Gaskets: L02/L03/YF2/YF3

Rubber 80 IRHD Moulded Compound to BS

EN681-1: Type WA,WC,WG or BS EN682: Type G

(other materials available on request)

Gaskets: A2E/A2H/XSXXG

Rubber 70 IRHD Moulded Compound to BS

EN681-1: Type WA, WC, WG or BS EN682: Type G

(other materials available on request)

Every effort has been made to ensure that the information contained in this publication is accurate at the time of publishing. Crane Ltd assumes no responsibility or liability for typographical errors or omissions or for any misinterpretation of the information within the publication and reserves the right to change without notice.

Large Diameter Flange Adaptors OD355 - 945mm to BS EN 1092-1 PN25 Drilling

Specifications

L = Distance back from end of pipe that must be rounded, meet tolerances, and free from any wrapping to ensure correct assembly.

Flange Adaptor Type	Flange Adaptor Section	Sleeve Length S (mm)	Distance L (mm)	Setting Gap X (mm)		Bolt Details		
				Min.	Max.	Bolt Dia.	Length (mm)	Torque (Nm)
Standard Sleeve	LO2	73	150	25	50	M12	140	55 - 65
Long Sleeve	LO3	123	200	25	100	M12	180	55 - 65
Standard Sleeve	YF2	87	150	32	76	M16	160	95 - 120
Long Sleeve	YF3	123	200	32	115	M16	190	95 - 120
Standard Sleeve	A2E	87	150	32	76	M16	160	95 - 120
Long Sleeve	A2H	125	200	32	115	M16	190	95 - 120
Standard Sleeve	XSXG	254	200	57	117	M16	400	95 - 120

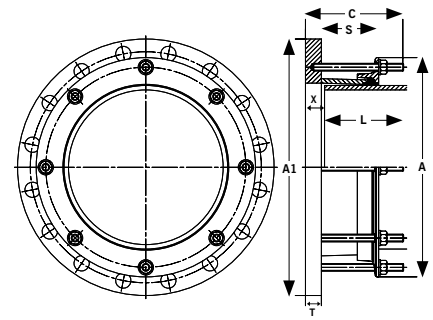

NOTES

- General** Viking Johnson manufacture flange adaptors to any pipe OD and flange drilling. If the product required is not shown in any of our tables please contact Viking Johnson who can provide the relevant information.
- Pressure** Working pressure is in accordance with the flange drilling. Site test pressure is 1.5x working pressure.
- End Restraint** Dedicated flange adaptors DO NOT resist end load due to the internal pressure - adequate external restraint must be provided by either anchoring the pipework or use of tie rods to restrain the flange adaptor and prevent pipe pull out.
- Tie Rods** When using tie rods to provide restraint, depending on the pipe OD & flange drilling the flange adaptor end ring may need to be notched to allow the tie rod to pass over. The table below provides details on :-
 A) Those products that do not require notching (i.e. there is no interference between the tie rods and end ring) - indicated by "Not Rqd."
 B) Those products where there is interference between the tie rod and end ring and do require notching, with the number of notches provided as standard indicated.
- Tie Rod Yield Strength** The number of notches indicated assumes the use of tie rods with a minimum yield strength of 725 N/mm².
 If tie rods with a lower yield strength are used, then depending on the working pressure an increased number than that specified in the table may be required; in this situation please advise Viking Johnson of the number of notches and we will accommodate your requirements.

Pipe OD (mm)	Pipe Material	Flange Drilling BS EN 1092-1		Tolerance on Pipe OD for Distance L		Gasket Mould No.	No. Notches In End Ring If Required	Flange Adaptor Section Type		Flange Adaptor Studs No. x Dia	Weight (kg)		Dimensions						Flange Adaptor Studs Length	
		Nominal	Drilling	(mm) +	(mm) -			Standard Sleeve	Long Sleeve		Standard Sleeve	Long Sleeve	Diameter A (mm)	Flange OD A1 (mm)	Flange Thickness T (mm)	Flange Bolts No. x Dia	Overall C Standard Sleeve (mm)	Overall C Long Sleeve (mm)	Standard Sleeve	Long Sleeve
355.6	Steel	350	PN25	1.6	1.6	J51LS	Not Rqd.	L02	L03	8 x M12	34.4	37.8	446	555	25	16 x M30	155	195	140	180
358.6	Coated Steel	350	PN25	1.6	1.6	J51LS	Not Rqd.	L02	L03	8 x M12	34.1	37.5	450	555	25	16 x M30	155	195	140	180
378	Ductile Iron	350	PN25	2.7	3.5	J52LS	8	L02	L03	8 x M12	32.2	35.8	469	555	25	16 x M30	155	195	140	180
406.4	Steel	400	PN25	1.6	1.6	J53LS	Not Rqd.	L02	L03	8 x M12	40.7	44.6	497	620	25	16 x M33	155	195	140	180
409.4	Coated Steel	400	PN25	1.6	1.6	J53LS	Not Rqd.	L02	L03	8 x M12	40.4	44.3	500	620	25	16 x M33	155	195	140	180
429	Ductile Iron	400	PN25	2.8	4.0	J54LS	8	L02	L03	8 x M12	38.2	42.3	520	620	25	16 x M33	155	195	140	180
457	Steel	450	PN25	1.6	1.6	J55LS	Not Rqd.	L02	L03	10 x M12	44.4	48.8	548	670	25	20 x M33	155	195	140	180
460	Coated Steel	450	PN25	1.6	1.6	J55LS	Not Rqd.	L02	L03	10 x M12	44.1	48.4	551	670	25	20 x M33	155	195	140	180
480	Ductile Iron	450	PN25	2.9	4.0	J56LS	10	L02	L03	10 x M12	41.4	46.0	571	670	25	20 x M33	155	195	140	180
508	Steel	500	PN25	1.6	1.6	J57LS	Not Rqd.	L02	L03	10 x M12	50.9	55.7	598	730	25	20 x M33	155	195	140	180
511	Coated Steel	500	PN25	1.6	1.6	J57LS	Not Rqd.	L02	L03	10 x M12	50.4	55.3	602	730	25	20 x M33	155	195	140	180
532	Ductile Iron	500	PN25	3.0	4.0	J58LS	10	L02	L03	10 x M12	47.4	52.4	624	730	25	20 x M33	155	195	140	180
610	Steel	600	PN25	1.6	1.6	J60LS	Not Rqd.	L02	L03	10 x M12	62.7	68.4	700	845	25	20 x M36	155	195	140	180
613	Coated Steel	600	PN25	1.6	1.6	J60LS	Not Rqd.	L02	L03	10 x M12	62.2	67.9	703	845	25	20 x M36	155	195	140	180
635	Ductile Iron	600	PN25	3.2	4.5	J61LS	10	L02	L03	10 x M12	58.3	64.2	726	845	25	20 x M36	155	195	140	180
711	Steel	700	PN25	1.6	1.6	J63LS	Not Rqd.	L02	L03	12 x M12	74.2	81.0	802	960	25	24 x M39	155	195	140	180
714	Coated Steel	700	PN25	1.6	1.6	J63LS	Not Rqd.	L02	L03	12 x M12	69.4	76.1	805	960	25	24 x M39	155	195	140	180
738	Ductile Iron	700	PN25	3.4	4.5	J63LS	12	YF2	YF3	12 x M16	82.5	90.0	849	960	25	24 x M39	169	195	160	190
813	Steel	800	PN25	1.6	1.6	J65LS	Not Rqd.	YF2	YF3	12 x M16	106.5	113.6	922	1085	25	24 x M45	169	199	160	190
816	Coated Steel	800	PN25	1.6	1.6	J65LS	Not Rqd.	YF2	YF3	12 x M16	83.8	113.0	906	1085	25	24 x M45	169	199	160	190
842	Ductile Iron	800	PN25	1.0	4.5	J65LS	12	YF2	YF3	12 x M16	100.0	107.5	950	1085	25	24 x M45	169	199	160	190
914	Steel	900	PN25	1.6	1.6	J117M	7	A2E	A2H	14 x M16	168.6	137.1	1038	1185	38	28 x M45	182	212	160	190
916	Coated Steel	900	PN25	1.6	1.6	J117M	7	A2E	A2H	14 x M16	167.9	136.3	1041	1185	38	28 x M45	182	212	160	190
945	Ductile Iron	900	PN25	1.0	5.0	J118M	14	A2E	A2H	14 x M16	156.1	124.0	1069	1185	38	28 x M45	182	212	160	190

Every effort has been made to ensure that the information contained in this publication is accurate at the time of publishing. Crane Ltd assumes no responsibility or liability for typographical errors or omissions or for any misinterpretation of the information within the publication and reserves the right to change without notice.

Large Diameter Flange Adaptors OD1016 - 1255mm to BS EN 1092-1 PN25 Drilling

Specifications

Pipe OD (mm)	Pipe Material	Flange Drilling BS EN 1092-1		Tolerance on Pipe OD for Distance L		Gasket Mould No.	No. Notches In End Ring If Required	Flange Adaptor Section Type		Flange Adaptor Studs No. x Dia	Weight (kg)		Dimensions						Flange Adaptor Studs Length	
		Nominal	Drilling	(mm) +	(mm) -			Standard Sleeve	Long Sleeve		Standard Sleeve	Long Sleeve	Diameter A (mm)	Flange OD A1 (mm)	Flange Thickness T (mm)	Flange Bolts No. x Dia	Overall C Standard Sleeve (mm)	Overall C Long Sleeve (mm)	Standard Sleeve	Long Sleeve
1016	Steel	1000	PN25	1.6	1.6	J119M	Not Rqd.	A2E	A2H	14 x M16	202.2	213.5	1140	1320	38	28 x M52	182	212	160	190
1019	Coated Steel	1000	PN25	1.6	1.6	J119M	Not Rqd.	A2E	A2H	14 x M16	200.7	212.1	1144	1320	38	28 x M52	182	212	160	190
1048	Ductile Iron	1000	PN25	1.0	5.0	J119M	14	A2E	A2H	14 x M16	188.3	199.9	1171	1320	38	28 x M52	182	212	160	190
1118	Steel	1100	PN25	1.6	1.6	J120M	Not Rqd.	A2E	A2H	16 x M16	218.1	230.6	1242	1420	38	32 x M52	182	212	160	190
1121	Coated Steel	1100	PN25	1.6	1.6	J120M	Not Rqd.	A2E	A2H	16 x M16	216.4	228.9	1246	1420	38	32 x M52	182	212	160	190
1152	Ductile Iron	1100	PN25	1.0	6.0	J121M	16	A2E	A2H	16 x M16	201.6	214.5	1275	1420	38	32 x M52	182	212	160	190
1219	Steel	1200	PN25	1.6	1.6	J121M	Not Rqd.	A2E	A2H	16 x M16	243.5	257.1	1343	1530	38	32 x M52	182	212	160	190
1222	Coated Steel	1200	PN25	1.6	1.6	J121M	Not Rqd.	A2E	A2H	16 x M16	242.0	255.6	1347	1530	38	32 x M52	182	212	160	190
1255	Ductile Iron	1200	PN25	1.0	6.0	J122M	16	A2E	A2H	16 x M16	224.8	243.4	1378	1530	38	32 x M52	182	212	160	190

Materials & Relevant Standards

Flange/End Ring

Steel to BS EN10025-2: Grade S275JR

Studs/Nuts/Washers

Studs - Steel to BS EN ISO898-1: Property Class 4.8

Nuts - Steel to BS4190: Grade 4

Washers - Stainless Steel to BS1449:Part 2: Grade 304S15

Coatings

Body, Flange & End Ring - Rilsan Nylon 11 to WIS 4-52-01 Part 1

Nuts and Studs - Sheraplex coated to WIS 4-52-03

Gaskets: L02/L03/YF2/YF3

Rubber 80 IRHD Moulded Compound to BS EN681-1: Type WA,WC,WG or BS EN682: Type G (other materials available on request)

Gaskets: A2E/A2H/XSXG

Rubber 70 IRHD Moulded Compound to BS EN681-1: Type WA, WC, WG or BS EN682: Type G (other materials available on request)

Every effort has been made to ensure that the information contained in this publication is accurate at the time of publishing. Crane Ltd assumes no responsibility or liability for typographical errors or omissions or for any misinterpretation of the information within the publication and reserves the right to change without notice.

Large Diameter Check list

Large Diameter is a bespoke product and Viking Johnson requires the following information to assist with the quotation process. This page can be copied from the brochure or a form is available on the website or directly from the Marketing Department.

Please fax back to: +44 (0)1462 443311 or email to: info@vikingjohnson.com

Company Name		Date	
Contact Name		Email	
Customer Address			
	Telephone		
	Fax		
	Quantity		
	Delivery Date		

Pipe Details

Outside Diameter		Pipe Coating <small>(Especially important on steel pipes)</small>	
Outside Diameter Tolerances			
Pipe Material <small>(Please tick)</small>			
Ductile Iron <input type="checkbox"/>	Cast Iron <input type="checkbox"/>	Steel <input type="checkbox"/>	Stainless Steel <input type="checkbox"/>
PVC <input type="checkbox"/>	PE <input type="checkbox"/>	HEP30 <input type="checkbox"/>	GRP <input type="checkbox"/>
ABS <input type="checkbox"/>	Clay <input type="checkbox"/>	Concrete <input type="checkbox"/>	Asbestos Cement <input type="checkbox"/>
Copper <input type="checkbox"/>	Lead <input type="checkbox"/>		
Other <small>(Please specify)</small>			
	Pipe Coating Thickness		
	Working/Test/Design Pressure		

Product Requirements

Coating Required		Flange Rating	
Gasket Grade Required or medium conveyed			
	Drilling Pattern		
	Locating Plugs <small>(If required)</small>		

Packaging & Carriage Requirements

--

Any Special Documents / Inspection Requirements

--

Any Other Special Requirements

--

South Moravia - Czech Republic

Water Transmission Lines

Large Diameter Dedicated Flange Adaptors – DN500

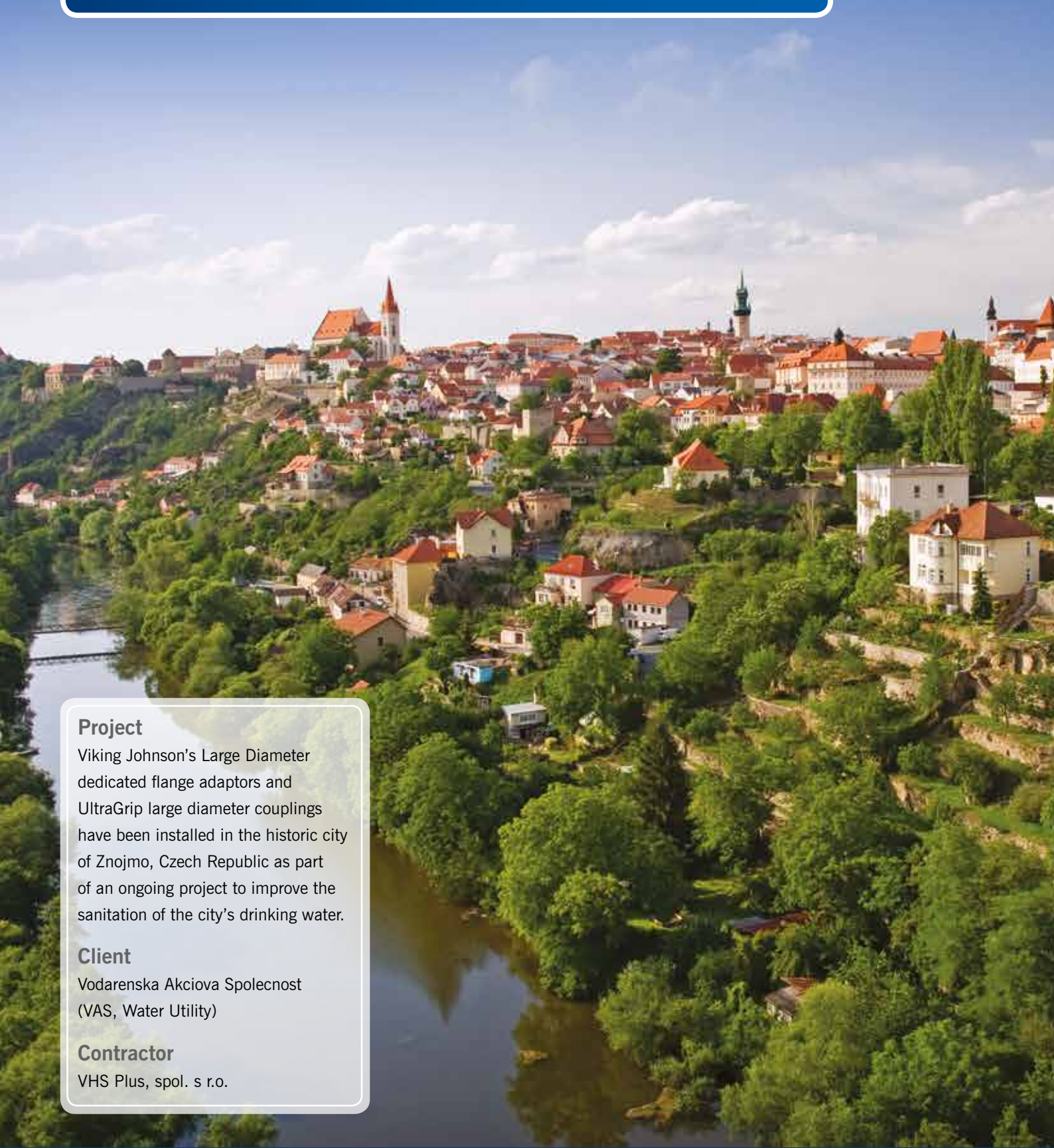

Project

Viking Johnson's Large Diameter dedicated flange adaptors and UltraGrip large diameter couplings have been installed in the historic city of Znojmo, Czech Republic as part of an ongoing project to improve the sanitation of the city's drinking water.

Client

Vodarenska Akciová Společnost (VAS, Water Utility)

Contractor

VHS Plus, spol. s r.o.

Tran-Sig-Ma spol. s r.o.
Dukelských hrdinů 19
170 00 Praha 7
Czech Republic

Tel: 00420 233 373 040,
00420 233 370 903,
00420 233 380 185
fax : 00420 233 380 302
E-mail: info@tran-sig-ma.cz
<http://www.tran-sig-ma.cz>



46-48 WILBURY WAY
HITCHIN, HERTFORDSHIRE
SG4 0UD. UNITED KINGDOM
TELEPHONE: +44 (0)1462 443322
FAX: +44 (0)1462 443311
EMAIL: info@vikingjohnson.com

www.vikingjohnson.com

Every effort has been made to ensure that the information contained in this publication is accurate at the time of publishing. Crane Ltd assumes no responsibility or liability for typographical errors or omissions or for any misinterpretation of the information within the publication and reserves the right to change without notice.



ISO 14001 • EMS 51874



ISO 9001 • FM 00311



To visit our Video Library go to:
www.youtube.com/user/CraneBSU

- Designed and manufactured under quality management systems in accordance with BS EN ISO 9001.
- Environmental Management System accredited to ISO 14001.
- For full terms and conditions, please visit our website.

DF9380_09_2017_GB

PIONEERS IN PIPE SOLUTIONS